

# Drayton

## Digistat +2RF/+3RF

### Programmable Room Thermostat Wireless

**Model:** RF700/22090

**Model:** RF701/22092

**Power Supply:**  
Battery - Thermostat  
Mains - Digistat SCR



**Invensys Controls Europe**

Customer Service Tel: 0845 130 5522

Customer Service Fax: 0845 130 0622

Technical Helpline Tel: 0845 130 7722

Website: [www.draytoncontrols.co.uk](http://www.draytoncontrols.co.uk)

Email: [customer.care@invensyscontrols.com](mailto:customer.care@invensyscontrols.com)

User Guide 06490099001 IssA



## Installation Instructions

### WARNING

If you do not have the knowledge to install the SCR safely then you must arrange for a competent electrician to install it for you. Wiring must conform to the current IEE regulations.

Prior to commencing the installation you must ensure the mains supply is switched off.

### INSTALLATION OF SCR RECEIVER

**Read all installation and commissioning instructions before proceeding. Do not switch on until ready to commission.**

The system wiring must be able to be fully disconnected from the mains supply by a switch incorporated in the fixed wiring having a contact separation of at least 3mm on both poles. Fused at 3A.

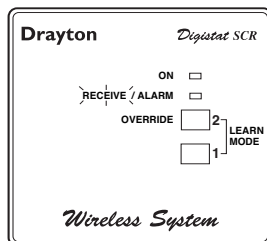

### LOCATION

The Digistat SCR (receiver) should be mounted in a convenient position, close to the boiler or central heating system.

For the best performance install in an open space, at least 30cm distance from any metal objects including wall boxes and boiler housing.

It is recommended that the SCR is mounted on the wall nearest the final location of the Digistat+RF programmable room thermostat and not less than 30cm from the boiler side panel.

**Warning: Installing the SCR too close to the metal side panel or mains cables may interfere with the radio signal.**

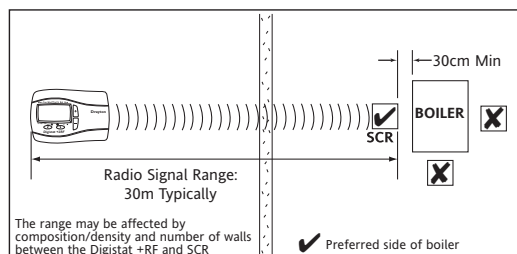

### FIXING (minimum wall plate clearances shown)

- Loosen the securing screws, remove the wallplate, and if surface wiring is to be used, snap out the cable entry strip on the bottom edge of the wallplate with a pair of pliers.
- Fix the wallplate, terminals at the top, either direct onto the flat wall using wall plugs and no 6 x 1" wood screws or on a plastic flush mounting single conduit box using M3.5 x 14 screws. Minimum wallplate clearances are shown.
- Complete the wiring to the SCR wallplate in accordance with the relevant diagram, to comply with current IEE regulations.
- Place the SCR onto the wallplate and tighten the securing screws.

### SCR wallplate clearances

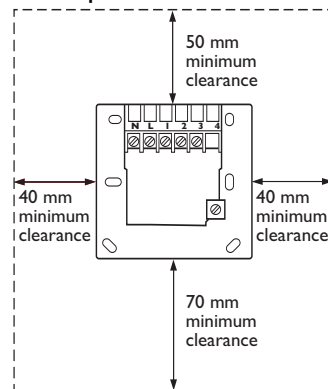

### Electrical

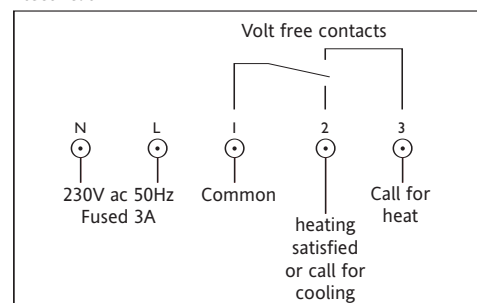

This product is double insulated and does not require an earth connection. The SCR should be wired to the boiler or central heating wiring using the correct type of cable or flex. The SCR should be wired in to replace hard wired room or programmable thermostats shown on the system or boiler wiring diagrams. Always check other manufacturers instructions for compatibility.

### Combi boiler basic wiring layout

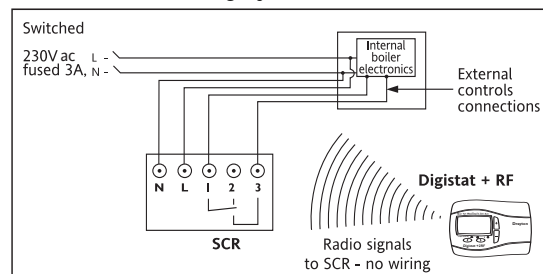

### Zone control basic wiring layout

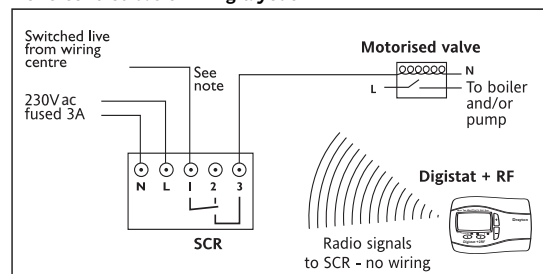

Note: If the Digistat +2RF or +3RF is used without a separate programmer, or the programmer is set constantly on it would be acceptable to link 'L' to '1' provided the output voltage required is 230V ac.

### COMMISSIONING THE DIGISTAT +2RF or +3RF 'WIRELESS SYSTEM'

- Turn off the power supply to the Digistat SCR (receiver unit) and leave for 5 seconds.
- Turn on power to SCR unit and check red light is on.
- Press override button No.2 and check the green light comes on and boiler fires.
- Press & hold down button No.1 (Keep depressed), then press No.2 and keep depressed. (The Red LED light will flash a couple of times and then it will go out)
- Now release both the buttons – (the two LED lights should come back on)
- Get the Digistat+2RF/+3RF unit and stand two metres away from the SCR unit with the Digistat+2RF/+3RF unit in your hand.
- Remove the battery cover and fit the batteries.
- The Red LED light on the SCR will now flash for approx. 7 seconds.
- This confirms that the radio signal is being sent and received.
- The Digistat+2RF/+3RF and the SCR are now successfully linked by a dedicated RF address.
- Install the Digistat+2RF/+3RF as follows:

### IMPORTANT: MULTIZONE INSTALLATIONS ONLY

If more than one 'wireless system' is fitted within the same property ie. for controlling 2 or more zones (multi-zone) it is essential that the Digistat +RF units are matched correctly to the relevant SCR. This is easily achieved by commissioning each Digistat +RF and SCR in turn.

### INSTALLATION OF THE DIGISTAT +2RF or +3RF PROGRAMMABLE THERMOSTAT

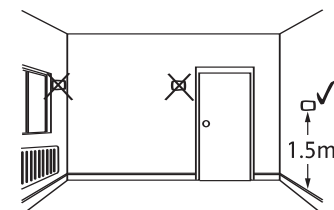
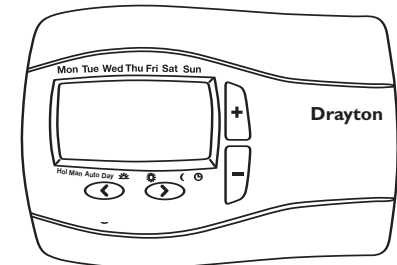

### Location

The Digistat +2RF/+3RF is a radio frequency device and for best performance should be mounted in an open space, not less than 30cm distance from any metal objects, including wall boxes.

Care should be taken to mount the Digistat +2RF/+3RF on a wall, in a position which is not subject to direct sunlight or draughts. Preferably it should be mounted on an inside wall about 1.5m (5ft) above the floor in a position where it can respond to room temperature, but away from the direct influence of radiators or other appliances giving off heat.

### Signal Strength

Before fixing the Digistat +2RF/+3RF to the wall it is recommended to first check the signal strength from that location.

To do this, remove the batteries, press and hold the + button whilst refitting the batteries. The display now shows rF which indicates that the Digistat +2RF/+3RF is continuously sending an OFF signal to the SCR (receiver). Leave the Digistat +2RF/+3RF in position and return to view the SCR. If the RED LED is continuously flashing, this indicates a good signal. If the RED LED is not flashing, this indicates a poor signal and you need to reposition the Digistat +2RF/+3RF until the RED LED is flashing. When the signal strength has been confirmed remove the batteries to cancel the test and follow the installation instructions 1-7 as follows.

## Installation

1. Remove the front cover using a flat screwdriver and separate from back plate (Fig 1).

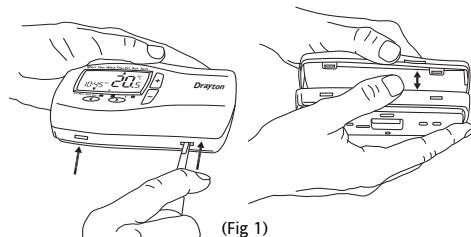

(Fig 1)

2. Fix the back plate directly onto the wall using suitable wall plugs and screws (Fig 2).

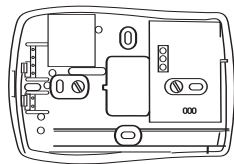

(Fig 2)

3. Replace the front cover by locating in position and pushing fully onto the back cover (Fig 3).



(Fig 3)

4. Remove the battery cover using a coin (Fig 4).
5. Install the 2 AA batteries provided (Fig 5).

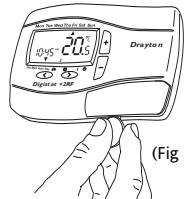

(Fig 4)

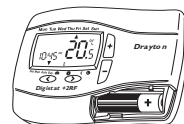

(Fig 5)

6. Replace battery cover (fig 6).

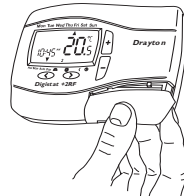

(Fig 6)

7. The Digistat +2RF/+3RF is now installed and will automatically start to control the room temperature according to the pre-set program 1 as shown in the User Guide. The display shows the correct time and date which is automatically set together with the actual room temperature.

## INSTALLER OPTIONS

If you wish to change any of the Installer Options as shown below, enter the Installer Option Menu from Auto mode by pressing < and + simultaneously for 5 seconds. Pressing < and + again for 5 seconds will exit the Menu and return to Auto mode.

Once the Installer Options screen has been selected (Fig 7), the < and > buttons allow you to scroll through the Menu (shown below). The + and - allow you to change values. Once a value has been changed pressing > before exiting the Menu will save the new setting. (Fig 8 shows Option 02 OFF).

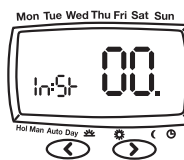

(Fig 7)

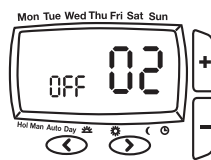

(Fig 8)

Installer Options	What is it	Select between		Default
02	Freeze Protection	On	Off	On
04	Low Set Point °C	5	High Limit	5
05	High Set Point °C	Low Limit	32	32
06	Delayed Start (Energy saving feature)	On	Off	Off
10	Valve Protection	On	Off	Off
11	Valve Protection Time (Mins)	1	5	3

### (Option 02)

#### Freeze Protection

Freeze protection will switch on the heating if the room temperature falls to 5°C and will then control the temperature at 7°C even if the Digistat+2RF/+3RF is in OFF mode.

The Freeze Protection default is ON.

To switch off the Freeze Protection mode enter the Installer Options Menu (Refer to Installer Options 02) and change to OFF. Press > to accept.

### (Option 04 & 05)

#### Low and High Limit set points.

The user temperature set points defaults are High 32°C and Low 5°C, to change these limits enter the Installer Options Menu (Refer to Installer Options 04 & 05).

### (Option 06)

#### Intelligent Delayed Start (Energy saving feature).

The Intelligent Delayed Start is an energy saving feature which automatically reduces the warm up time for the heating system. As the weather becomes milder, Intelligent Start will delay the heating start times so that fuel is not wasted bringing the room up to temperature earlier than necessary.

Note: Intelligent Delayed Start only applies in Auto mode.

Intelligent Delayed Start default is in OFF mode.

To switch ON Intelligent Delayed Start enter the Installer Options Menu (Refer to Installer Options 06).

Note the Intelligent Delayed start option is not suitable for Hydronic underfloor application. Ensure Installer option 06 is set to OFF before final commissioning for Hydronic underfloor application.

### Special Note:

**If the Intelligent delayed start feature is enabled, (Off changed to On in Installer option 06), please inform the end user of this feature.**

**The following special note has been added to the user instruction to explain the adjustment requirement:**

When the delay period is operating indicated by the flame symbol flashing (Fig 12), pressing any button returns the Digistat +2/3RF to auto mode allowing normal button operation until the next time/ temperature event, when it will resume the delay start mode or follows the Holiday, Manual, Override or Off modes as selected.

Changes to the installer options and pre-set programmes must be made with the flame symbol not flashing.

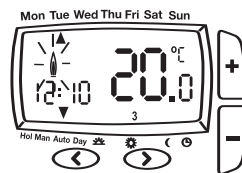

(Fig 12)

### (Option 10)

#### Valve Protection

In some hydronic heating systems there may be a requirement to protect the valve by operating it once a day, for a given period, without bringing on the heating system.

If valve protection is selected the valve will be operated for a period as shown in Valve protection time (mins).

Valve protection time every day at 10.00am.

Valve protection default is OFF.

To enable the valve protection mode enter the Installer Options Menu (Refer to Installer Option 10).

### (Option 11)

#### Valve Protection time (mins).

Valve protection time can be set between 1 and 5 minutes (default 3 minutes).

To change this once a day on time enter the Installer Options Menu (Refer to Installer Option 11).

**Digistat +RF Programmable Room Thermostats are available in 2 models.**

**Digistat +2RF = 24 Hour**, Programs are the same every day (Monday to Sunday)

**Digistat +3RF = 5-2 day /7day**, allows you to set programs for week days and weekends or different programs for every day of the week.

**Display Error code E1**

When the display shows an error code (E1) this indicates a sensor fault and the heating system will remain Off. Please contact your local heating service engineer to replace your Digistat +2RF/3RF.

## Technical Data Digistat +2RF/+3RF

Power supply	2 X 1.5V IEC LR6 (AA) alkaline batteries
Battery life	2 years typical
Ambient temperature	Operating 0°C to 40°C Storage - 20°C to 55°C
Ambient humidity (non condensing)	Operating 25% to 90% Storage 15% to 95%
Temperature range	5°C to 32°C
Accuracy (between 5°C & 32°C)	0.5K
Timing resolution	1 minute
Temperature resolution	0.5K
Ball pressure test	75 °C
Pollution situation	Degree 2
Protection level	IP30

## Technical Data SCR (Receiver)

Applicable Standards:	BS EN60730-1 BS EN60730-2-7 BS EN60730-2-9 ETSI EN 300 220-3 Electromagnetic compatibility and radio spectrum Matters (ERM); Short Range Devices (SRD). ETSI EN 301 489-3 Electromagnetic compatibility and radio spectrum Matters (ERM); EMC standard for radio equipment and services; Part 3: Specific conditions for Short Range Devices (SRD) operating on frequencies between 6 kHz and 40 GHz. 73/23/EEC Low Voltage Directive 89/336/EEC EMC Directive 93/68/EEC Marking Directive 1999/5/EC R&TTE Directive
Power Supply:	230V ac 50Hz
Switch Type & Rating:	SPDT (voltage free) 2(1)A 230V ac or 24V ac/dc
Wiring:	Designed for fixed wiring only, to comply with current IEE regulations.
Reception Frequency:	433 MHz

## Dimensions

