

# Simp-L-Fit

## BIFLO

# Plug-in Heating Control Pack with Drayton and Tempus, Lifestyle or Switchmaster products

## Installation and wiring guide

Wiring centres, designed to simplify wiring installations and circuit checking, lose some of their value if they are not in themselves easy to understand and use. The *Simp-L-Fit Plug-in Wiring Centre* has been introduced to meet this requirement in the following ways:

- Plug in connections are used on the mid position valve and cylinder thermostat which reduces installation time and eliminates the possibility for incorrect wiring.
- Each terminal is clearly printed i.e. Pump L, E and N so as to reduce confusion.

*N.B. All wiring must be to the latest I.E.E. standards and carried out by a competent, qualified installer.*

## Contents

- Programmer
- Mid-position valve
- Room thermostat
- Cylinder thermostat
- **Simp-L-Fit plug-in wiring centre**

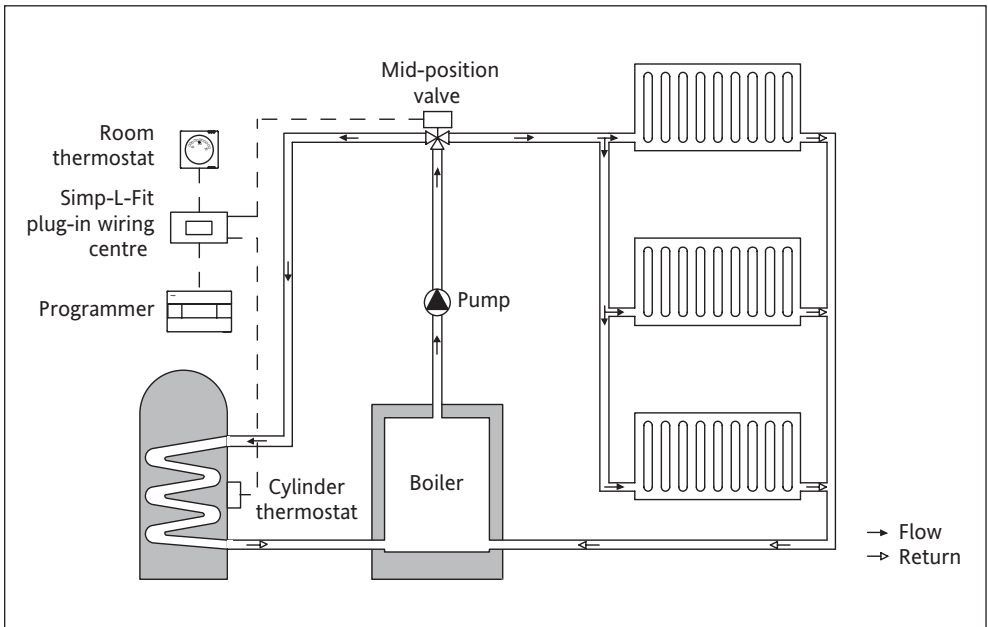

# Programmer *See separate instruction leaflet*

## Motorised valve

### Installation

DO NOT ATTACH THE ACTUATOR UNTIL THE VALVE BODY HAS BEEN FITTED AND ALL PIPEWORK CONNECTIONS ARE MADE. ENSURE MINIMUM CLEARANCES ARE ADHERED TO (see below).

Install the valves in a clean, dry location where the ambient temperature does not exceed 52°C. The body must not be installed with the actuator below the horizontal so as to avoid any potential ingress of water from leaking pipe work. The body should be installed such that the actuator release button, manual lever and motor cover retaining screw are left accessible and the valve position indicator visible when the actuator is fitted.

Cut connecting copper tubes to allow 10-15mm penetration into the valve body, and ensure pipe ends are square and free of burrs. Slip the compression nuts over the ends of

the pipe followed by the copper olives so that these fit into the threaded sections of the nuts. Offer up the valve body, screw on and tighten the compression nuts by hand until finger tight and then tighten fully with a spanner or adjustable wrench, using another wrench on the flats of the body to stop it rotating. Care must be taken not to overtighten or to put any mechanical force on the plastic parts of the valve

Before the actuator is fitted to the body, the manual lever must be moved to the right and pushed in to lock in place (this manual lever is used when filling, venting and draining the installation).

Position the actuator over the spindle ensuring the two locating pegs on the actuator mate with bosses on the body and press down. The actuator will lock into place automatically (an audible click will be heard).

### Operation

Mid position valves allow the flow of water from the valve inlet to be directed to either of two outlets, or through both at the same time. Signals from room and cylinder thermostats enable the valve's electronic circuitry to close either one of the outlet ports or to hold the swivel seal in the mid position to leave both outlets open.

### Valve position indicator

W = Domestic hot water (Port B)  
M = Both water and heating (Ports A and B)  
H = Central Heating (Port A)

### Plug-in connections

Once the fitting of the valve and actuator is complete, simply push the connector into the socket marked "Mid-Pos".

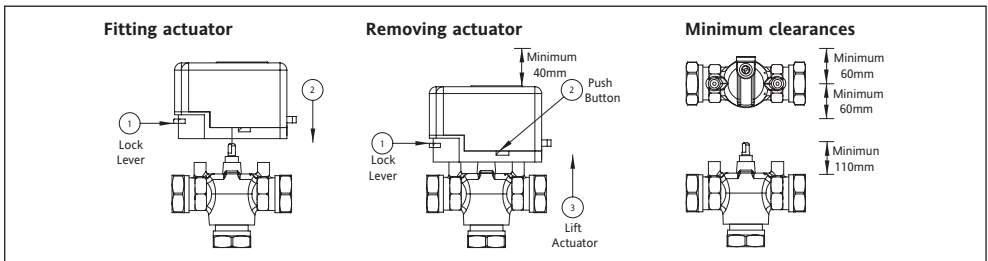

## Room thermostat

### Location

Care should be taken to mount the thermostat in a position, which is not subject to direct sunlight or draughts. Preferably it should be fixed on an inside wall about 1.5m above the floor, in a position where it can respond to room temperature, but away from the direct influence of radiators or other appliances giving off heat.

### Fixing

1. Loosen the securing screws, remove the wall-plate and, if surface wiring is to be used, snap out the cable entry strip on the bottom edge of the wall plate with a pair of pliers.
2. Fix the wall-plate, terminals at the top, either direct on to a flat wall using wall plugs and No.6 x 1" woodscrews or on a flush mounting single conduit box using M3.5 x 14 screws

3. Complete the wiring to the wall-plate in accordance with the diagram.

*Note: The thermostat is for fixed wiring only and is double insulated, the earthing continuity (loop) terminal is only for convenience.*

4. Plug the thermostat on to the wall-plate and tighten the securing screws.

# Cylinder thermostat

The thermostat should be installed approximately one third of the way up the hot water cylinder, and at the front for ease of access. With pre-insulated cylinders, mark the position and size, and remove just enough insulation to allow the thermostat to fit against the metal of the cylinder in the recess formed.

The base of the thermostat should be held in good contact with the metal of the hot water cylinder.

The plastic covered spring fixing cable should be cut to an

unstretched length of approximately 2½" – 3" less than the circumference of the cylinder and the hook and eyelet screwed into the ends. Stretch the cable around the cylinder, above the insulation, and position it in the groove across the front of the thermostat. Engage the hook and eyelet.

The two setting marks outside the temperature scale provide positive ON and OFF positions to assist with commissioning or checking the system operation. Rotate the setting

arrow fully clockwise for ON, and anticlockwise for OFF.

With a screwdriver, position the setting arrow at the desired nominal hot water temperature.

A popular setting is 60°C but if this is not exactly suitable simply adjust up or down as appropriate.

## Plug-in connections

Once the cylinder thermostat is fitted, simply push the connector into the socket marked "Cylinder Stat".

# Simp-L-Fit plug-in wiring centre

The plug in wiring centre can accept cable entry from either fixed wiring rear access or via surface mounted/conduit entry.

The cables should be connected to the relevant terminal blocks as detailed in the connection diagrams below and the mid position valve and cylinder thermostat should be plugged into the correct connector (these are clearly labelled on the PCB).

Site the Plug-in wiring centre to allow the cables from both the mid position valve and cylinder thermostat to be plugged in.

**IMPORTANT – ensure the switch is in the BIFLO position**

If using a boiler with a pump run on feature cut the link wire on the PCB. Please consult boiler manufactures literature for wiring

details and features

Cable clamps are provided (if required) for the mains, pump, boiler, programmer, and room

thermostat. The connections for the valve and cylinder thermostat are provided with integral cable clamps (see drawing *Cable clamps*).

## Connections

### Programmer

	N	L	1	2	3	4
Lifestyle LP722, LP522, LP241, LP112 Tempus 3, 4, 6, 7, SM2	N	L	1	2	3	4
Switchmaster 400, 600	N	L	–	–	3	1
Switchmaster 805, 905, 9001	N	L	4	2	3	1

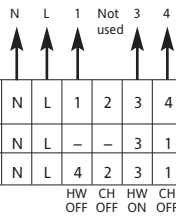

### Connections

The letters/numbers printed at the tip of each arrow represent the Simp-L-Fit plug-in wiring centre terminals to which those leads or terminals should be connected.

### Boiler and pump

Please refer to manufacturer's literature for wiring details.  
Cut link on PCB for pump overrun boilers.

### Room Thermostat

	L/1	N	3
RTS 1 and 2	L	N	3
Digistat	1	–	3
Function	COM	N	CALL

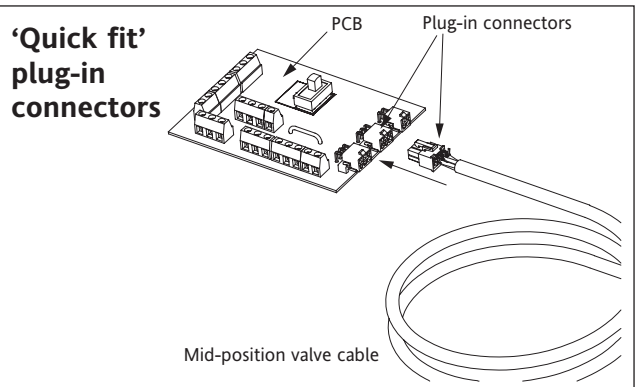
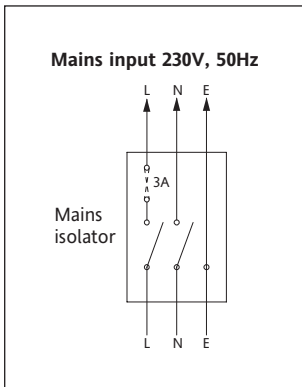
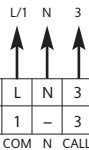

## Cable clamps

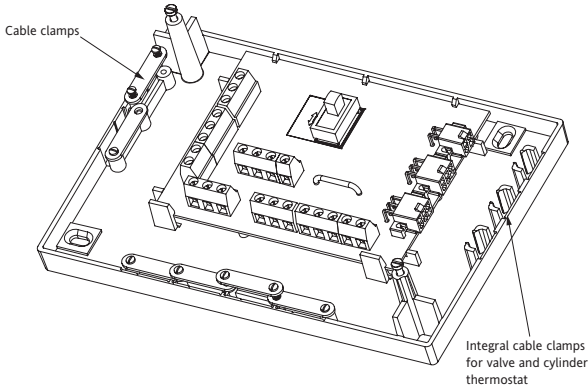

## First fix diagram

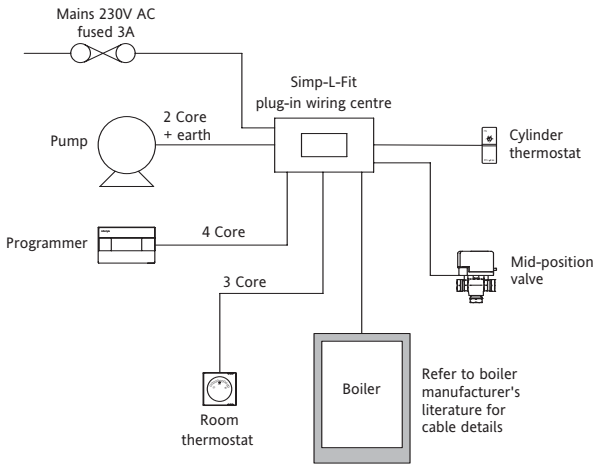

Note : The mid-position valve and cylinder thermostat are supplied with 1m and 1.5m of cable respectively and are fitted with 'quick fit' plug in connectors

**WHERE ANY DOUBT EXISTS, PLEASE SEEK PROFESSIONAL ADVICE**



**Invensys**

Climate Control Systems Europe

Customer Service Tel: +44 (0) 845 130 5522

Customer Service Fax: +44 (0) 845 130 0622

Technical Helpline Tel: +44 (0) 845 130 7722

Website: [www.climate-eu.invensys.com](http://www.climate-eu.invensys.com)

Email: [customerservices@invensys.com](mailto:customerservices@invensys.com)

**CONFORMS TO THE ESSENTIAL REQUIREMENTS OF THE FOLLOWING DIRECTIVES**

89/336/EEC

– Electromagnetic compatibility

73/23/EEC

– Low Voltage Directive



*Invensys Climate Controls Systems Europe continuously seek to improve products and reserve the right to make changes without notice*

*Every effort has been made to simplify the instructions and to ensure accuracy. However, the information is provided for guidance only and Invensys Climate Control Systems Europe are unable to accept liability for incorrect installation.*

06490024001 Iss. A

1102